

NOTES: DIMENSIONS IN [ ] ARE IN INCHES.

DIAMETERS MUST BE CONCENTRIC WITHIN 0.25 [ ] T.I.R.

(B)

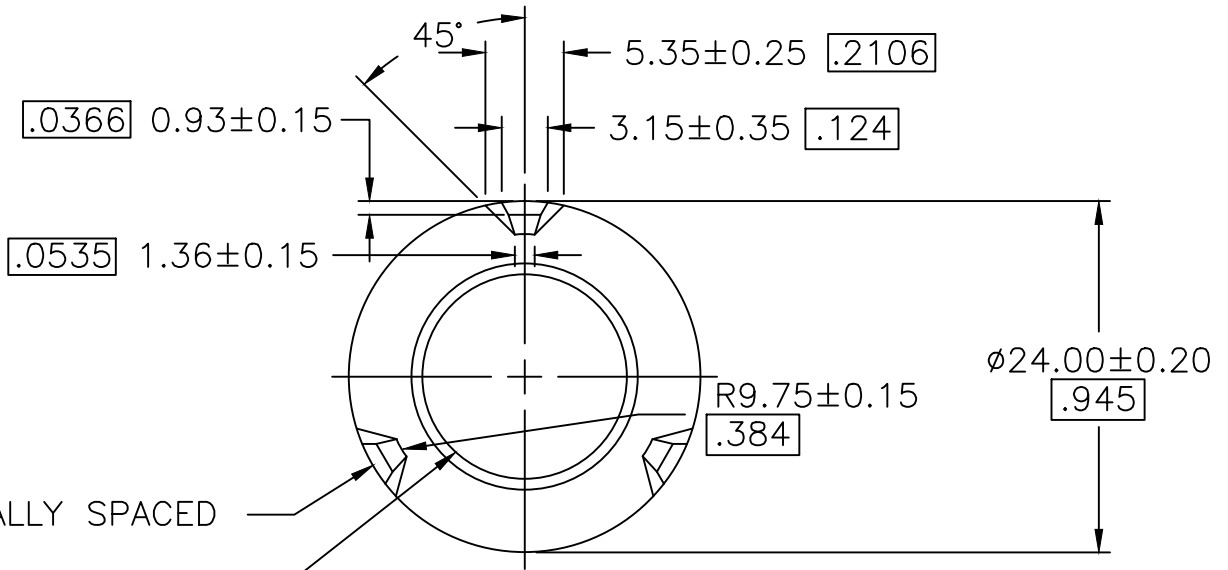

3 PROJECTIONS EQUALLY SPACED

$14.00 \pm 0.15$   
[ .551 ]  
HOLE DIA.

DECKER FASTENERS IDENT.  
MARKING "DF" (A)

C/N	S	CHANGE	DATE	DR	CH	OK
	A	ADDED "DF" IDENT	2/22/11	MAK		
	B	ADDED TIR NOTE	2/22/11	MAK		
	C					
	D					
	E					



CONFIDENTIAL

THIS DOCUMENT IS THE EXCLUSIVE PROPERTY OF DECKER MANUFACTURING CORPORATION AND IS TO BE RETURNED TO THE COMPANY UPON REQUEST. THE CONTENTS ARE NOT TO BE USED IN ANY MANNER DETRIMENTAL TO THE INTERESTS OF THE COMPANY. THEY ARE NOT TO BE DISCLOSED OR REPRODUCED IN WHOLE OR IN PART WITHOUT EXPRESSED CONSENT.

PART NAME			ROUND WELD NUT		
CUSTOMER PART NO.					
MATERIAL			C1010 STEEL		
FINISH		PLAIN	SCALE		2X
DRAWN BY	DATE	PART NO.			
MAK	10/11/10	625-2542			
CHECKED BY	APPROVED BY				