

NOTE:
DIAMETERS TO BE CONCENTRIC
WITHIN 0.25 T.I.R.

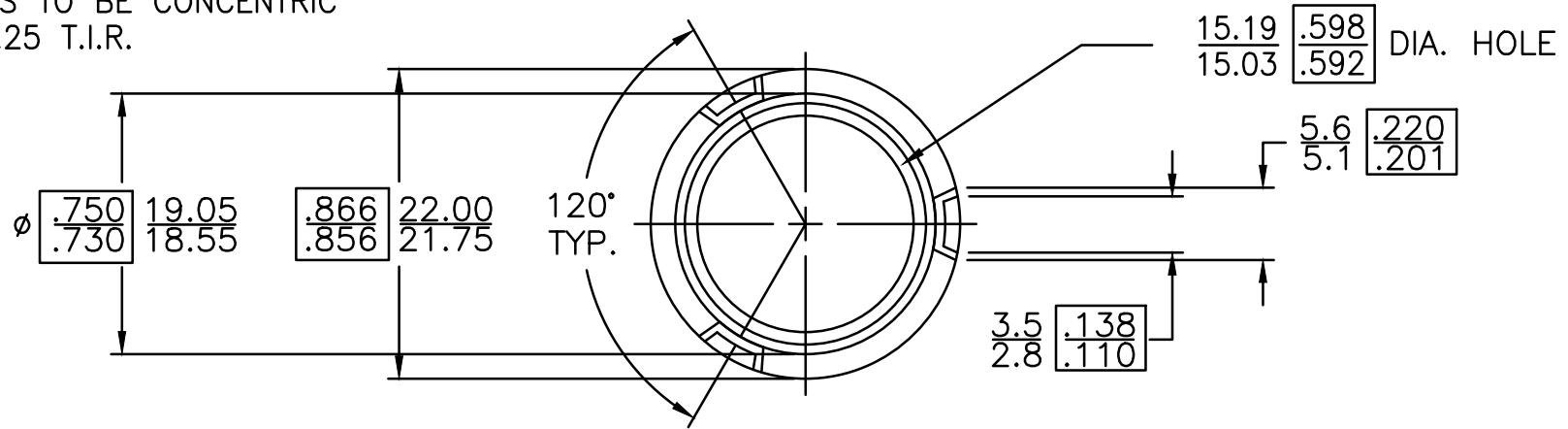

C'SINK 80°/100° INCL.
MAT BE ROUNDED

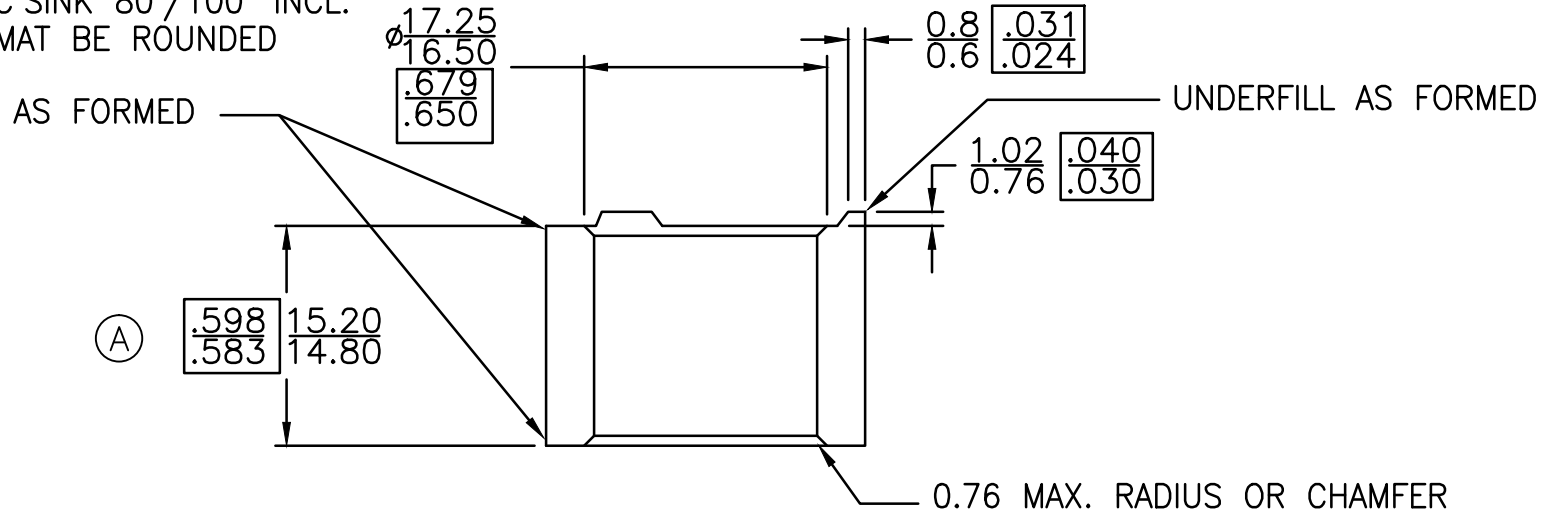

C/N	S	CHANGE	DATE	DR	CH	OK
	A	WAS 15.14/14.86	12/1/04	MAK		
	B					
	C					
	D					
	E					



THIS DOCUMENT IS THE EXCLUSIVE PROPERTY OF DECKER MANUFACTURING CORPORATION AND IS TO BE RETURNED TO THE COMPANY UPON REQUEST. THE CONTENTS ARE NOT TO BE USED IN ANY MANNER DETRIMENTAL TO THE INTERESTS OF THE COMPANY. THEY ARE NOT TO BE DISCLOSED OR REPRODUCED IN WHOLE OR IN PART WITHOUT EXPRESSED CONSENT.

PART NAME		
RD. WELD NUT		
CUSTOMER PART NO.		
MATERIAL		
C1010 STEEL		
FINISH		SCALE
PLAIN		2X
DRAWN BY	DATE	PART NO.
MAK	2/4/04	150-7855
CHECKED BY	APPROVED BY	